

## *Role of Micro sources within Micro grid*

**Mr.Sandeep A. Kale**

Lecturer, Electrical Engineering Department  
SVSS College Of Engineering & Research  
Nagpur, India  
e-mail:sandeep\_kale2005@yahoo.co.in

**Mr.P.P.Jagtap**

Asst.Prof., Electrical Engineering Department  
G.H.Raisoni College of Engineering  
Nagpur, India  
e-mail:ppjagtap@yahoo.com

**Dr. J.B.Helonde**

Principal  
ITM  
Nagpur, India  
e-mail:jbhelonde@gmail.com

**Abstract** — Microgrid is a grid which helps to provide the generation in case of Grid failure. Microgrid is a new concept in the arena of green power generation, which is substantially attracting many researchers' interest due to its potential to extend the applications of the distributed generations, especially the renewable energy. Microgrid is a low voltage electrical network with small distributed generators, energy storage devices, controllable loads & protection. A MicroGrid can increase the reliability of energy supplies by disconnecting from the grid in the case of network faults or reduced power quality models for the main microsources/non conventional energy sources including Wind Turbines, Diesel Generator and fuel cells are properly established, in addition to the basic models of the power electronics interfaces being given simultaneously. This project emphasizes modelling & simulation of a Microgrid to account for both the transient and steady-state system characteristics; MATLAB/Simulink is used for the simulation, which can simulate both the steady and dynamic characteristics of the three-phase Microgrid. The result shows that there is an increase in power generation when the microsources/ non conventional energy sources connected within Microgrid which helps in different applications and also in case of grid islanded mode.

**Keywords-** Modeling; Microgrid; Non conventional Energy Sources; Renewable generation;

### **I INTRODUCTION**

A Microgrid is a variable/low voltage electrical network with small Distributed Generators (DGs), Energy Storage Devices, Controllable Loads & Protections. A distributed energy system running parallel or within the national grid system is called a Microgrid. Microgrid is a new concept in the arena of green power generation, which is substantially attracting many researchers' interest due to its potential to extend the applications of the distributed generations, especially the renewable energy. The Microgrid concept has been proposed as a solution to the conundrum of integrating large amounts

of micro-generations without disrupting the operation of the utility network.

The Microgrid model is capable of representing the dynamic behavior of micro-grids during either grid-connected or islanded operation. Currently a lot of research is being undertaken into Microgrid technology and some topology architectures have been presented, but little has been done on the models to be integrated into a Microgrid. Modeling and simulation techniques of the system, so as to develop an appropriate control system, contribute to the leading front of the Microgrid research. This paper emphasizes mainly on the modeling of a Microgrid to account for both the transient and steady-state system characteristics, and the islanded mode operation in which the following models are established: Wind Turbines, Diesel Generator, Fuel Cell and Inverter.

### **II STRUCTURE OF MICROGRID**

Figure 1 shows the Schematic Microgrid architecture, which consists of a group of radial feeders A, B and C together with a collection of loads. The radial system is normally connected to the large power distribution system through a separation device called point of common coupling, which is usually a static switch. Feeder A indicates the co-existence of several microsources with one providing both power and heat supply. Each feeder has a specific circuit breaker. As loads change randomly, the local Non conventional sources/microsources either increase or decrease their power output to hold balance of the power flow within the Microgrid. In Figure 1, feeders A and B are attached with critical loads which require generations from the Non conventional sources/microsources, while feeder C is assumed to have non-critical loads which can be shed off if necessary. When the Microgrid is grid-connected, the power from the local generation can be directed to the non-sensitive loads; when there are disturbances on the large distribution system the Microgrid can be islanded for independent operation.

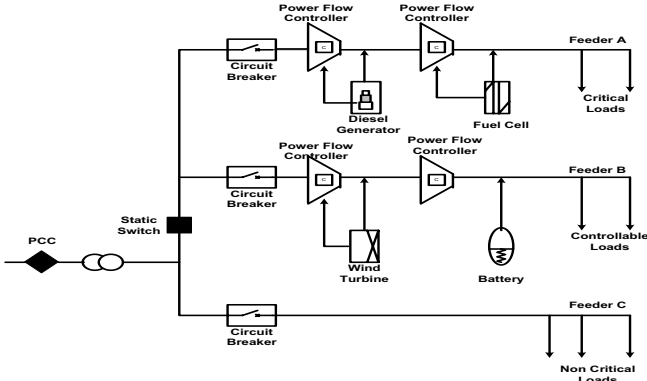

Fig 1 Schematic Microgrid Architecture

### III. MODELLING OF THE MICROGRID

A detailed description of the models adopted for solid oxide fuel cells and the diesel generator is modeled as composed of a prime mover, a governor and a generator unit. The wind turbines comprise several subsystems that are of aerodynamic type and modeled independently. The generator is a mechanical one and the power converters are fitted in case of variable speed wind turbines. Storage batteries are modeled as a constant DC source coupled with a static converter to be connected to the local electrical network. Usually its active power is injected into the Microgrid proportionally to the frequency deviation. Microturbine generators, and fuel cell generation systems have to be connected through inverters, and hence a simple model is hereby adopted for the inverters..

#### A. DIESEL GENERATOR MODEL

Diesel Engines are very old system, developed more than 100 years ago, were among the first ones to have been used in the distribution generator technologies. There are many methods already proposed for diesel generator modeling. Here the Diesel generator model includes a diesel engine system and a generator unit. From the control system point of view, a diesel engine can be considered as a speed-feedback system. Fig.2 shows the diesel engine system model including a prime mover and a governor.

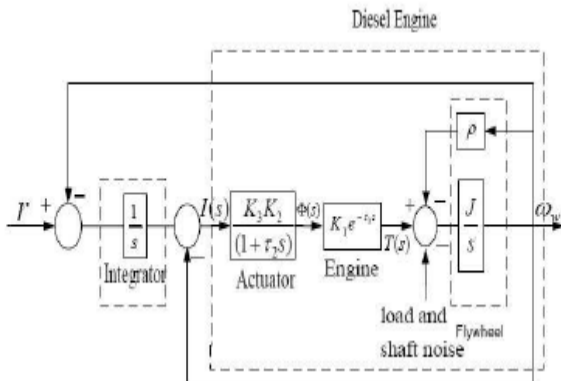

Fig 2 Block Diagram of Diesel Engine system

The general structure of the fuel actuator system is usually represented as a first-order phase-lag sector, which is characterized by a gain  $K_2$ , a time constant  $\tau_2$ , and the current driver constant  $K_3$  in Equation 1. The output of the actuator is the fuel-flow  $\phi(s)$ , while the input is current  $I(s)$ .

$$\Phi(s) = \frac{K_3 K_2}{(1 + \tau_2 s)} I(s) \quad \text{----- (1)}$$

Fuel Flow  $\phi(s)$  is then converted into a mechanical torque  $T(s)$ , with a time delay and an engine torque constant  $K_1$ . The flywheel represents the complex dynamic effects of the engine inertia, the angular speed  $w$  of the flywheel, the viscous friction coefficient and the loaded alternator.. The noise itself is an inherent property of an internal combustion engine. An integrator is added between the reference signal  $r$  and the engine actuator. It is necessary to eliminate the speed droop in steady-state operation by raising the order of the whole system as shown in Fig. 2. It has additional improvements to the results without using the integrator. The typical set of per unit values used in the simulation is taken from [2].

#### B. FUEL CELL

There are five different types of Fuel Cells given below-

- *AFC* – Alkaline Fuel Cell
- *PEFC/PEM* – Polymer Electrolyte Fuel Cell / Proton Exchange Membrane
- *PAFC* – Phosphoric Acid Fuel Cell
- *MCFC* – Molten Carbonate Fuel Cell
- *SOFC* – Solid Oxide Fuel Cell

The *SOFC* model is described in this paper. A power generation fuel cell system has the following three main parts:

**Fuel processor:** The fuel processor converts fuels such as natural gas to hydrogen and by product gases.

**Power section:** The power section generates the electricity. There are numerous individual electrochemical fuel cells in the power section.

**Power conditioner:** The power conditioner converts *dc* power to *ac* power output and includes current, voltage and frequency control.

- (a) Although CO can be a fuel in SOFC, the CO-shift reaction is chemically favoured with present designs and operations if the fuel gas contains water. The CO-shift reaction is:

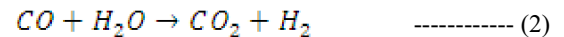

Based on this, we assume that only  $H_2$  and  $O_2$  enter into the fuel cells.

- (b) Fuel utilization is the ratio between the fuel flow that reacts and the input fuel

flow.

$$U_f = \frac{q_{H_2}^r}{q_{H_2}^{in}} \quad \text{-----} \quad (3)$$

Typically, 80 - 90% fuel utilization is used.

- (c) The real output current in the fuel cell system can be measured, so the input fuel flow can be controlled to control  $U_f$  at 85%, so

$$q_{H_2}^{in} = \frac{2K_r I_{fc}^r}{0.85} \quad \text{-----} \quad (4)$$

- (d) It is assumed that the anode is supplied with only  $H_2$  and the cathode with  $O_2$  only, so that the only reaction that occurs in the fuel cell is:



So, the stoichiometric ratio of hydrogen to oxygen is 2 to 1. Oxygen excess is always taken in to let hydrogen react with oxygen more completely. Simulation in our fuel cell system shows that  $r_{H_2O}$  should be kept around 1.145 in order to keep the fuel cell pressure difference below 4 kPa under normal operation. So the input oxygen flow  $q_{O_2}^{in}$  is controlled to keep  $r_{H_2O}$  at 1.145 by speed control of the air compressor.

$$q_{O_2}^{in} = r_{H_2O} \cdot q_{H_2}^{in} \quad \text{-----} \quad (6)$$

- (e) The potential difference between the anode and the cathode is calculated using the Nernst's equation and Ohm's law:

$$V_{fc}^r = N_0 \cdot \left[ E_0 + \frac{RT}{2F} \times \ln \frac{P_{H_2} \cdot P_{O_2}^{1/2}}{P_{H_2O}} \right] - r \cdot I_{fc}^r \quad (7)$$

Where,  $E_0$  – The Voltage associated with reaction free energy (V)

$P_{H_2}$ ,  $P_{O_2}$ ,  $P_{H_2O}$  – The Partial Pressures of the component (N/m<sup>2</sup>)

$N_0$  – The number of cells

$r$  – The Electrical resistance of the fuel cell or ohmic loss ( $\Omega$ )

$R$  – The Universal Gas constant (J/mol K)

$T$  – The channel or Absolute Temperature (K)

$F$  – The Faradays constant (Coulombs/mol)

$I_{fc}^r$  – The reaction or Output Current (A)

The following differential equations describe the

chemical behaviour of the reaction.

$$\frac{dp_i}{dt} = \frac{RT}{V_{ch}} \frac{dn_i}{dt} \quad (8)$$

and

$$\frac{dn_i}{dt} = q_i^{ch} = (q_i^{in} - q_i^r) \quad (9)$$

Where,

$q_i^{in}$  is the flow of the  $i^{th}$  element of input,

$q_i^r$  is the flow of  $i^{th}$  element that reacts.

The chemical response in the fuel processor is usually slow, as it is associated with the time to change the chemical reaction parameters after a change in the flow of reactants. This dynamic response function is modelled as a first-order transfer function with a 5s time delay constant ( $T_f$ ). The dynamic response function of the flow is also modelled as a first-order transfer function with the time delay constant of the respective element,  $\tau_{H_2}$ , for the response time of hydrogen flow,  $\tau_{O_2}$  for oxygen and  $\tau_{H_2O}$  for water flow. The output of this model provides the potential difference between anode and cathode and  $I_{fc}^r$  the reaction current. A conventional battery can be connected to the DC output of the fuel cell to provide fast response to load step increases.. The system consists of Inverter. On the basis of these above equation the SOFC system dynamic model is made [4].

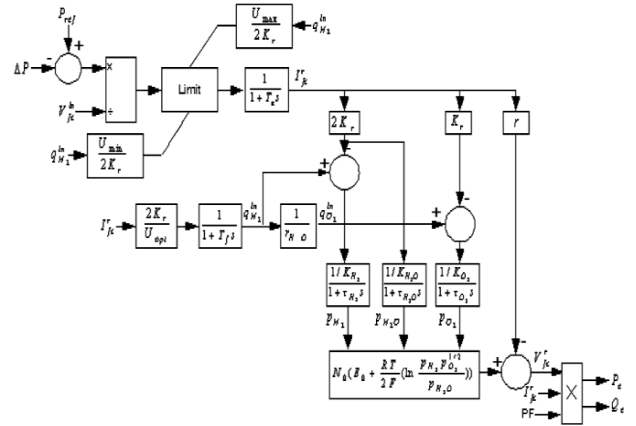

Fig 3 SOFC system dynamic model

### C WIND TURBINE

**Wind Energy:** Wind Energy is converted through friction into diffuse heat throughout the Earth's surface and the atmosphere. Wind power is the conversion of wind energy into a useful form, such as electricity, using wind turbine.

**Wind Turbine:** To reduce the price further and to make wind energy more competitive with other production methods, wind turbine manufacturers are concentrating on bringing down the price of the turbines themselves. A wind turbine transforms the kinetic energy in the wind to

mechanical energy in a shaft and finally into electrical energy in a generator..

It is considered that the wind turbine is equipped with asynchronous generator. Wind generators are considered as asynchronous motors in generating operation (negative loads). The rating of the wind turbine generator is 200kW. The asynchronous wind turbines are largely used for the production of electricity particularly in remote areas. The figure 4 shows the wind turbine model [10]. The Wind Turbine block uses a 2-D Lookup Table to compute the turbine torque output ( $T_m$ ) as a function of wind speed ( $w\_Wind$ ) and turbine speed ( $w\_Turb$ ).

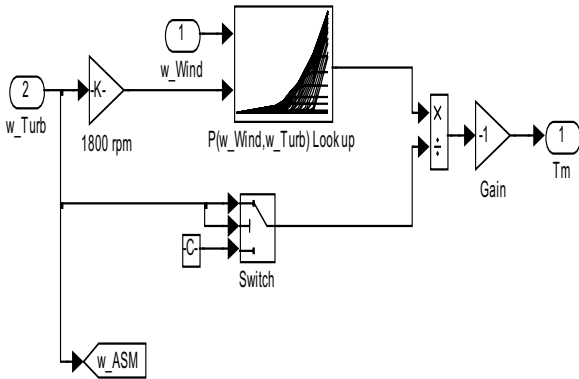

Fig 4 Wind Turbine Model

A wind turbine shown above in which a constant wind speed of 10m/s & a variable turbine speed or rotor speed ( $\omega_m$ ) are applied to a look up table block which will give the power generated by wind turbine. In order to generate the torque power gets divided by variable turbine speed and finally multiplied by -1 by using the gain block to generate a negative torque which is applied to asynchronous generator.

#### IV. SIMULATIONS AND VALIDATION

The Microgrid and distributed generators are modeled within a platform by MATLAB/Simulink, in which a 300kW diesel generator, a 200kW wind turbine generator, the controllable loads and a 100kW fuel cell are incorporated into the Microgrid. To examine the validity of simulation platform, various operating conditions and disturbances are considered, such as the dynamic behaviour of micro-grids during either grid is connected or islanded, disconnection of microsourses from Microgrid or load changes in the Microgrid, different wind speed etc. To examine the validity of the simulation platform, various operating conditions and disturbances are considered, such as different wind speed, disconnection from the main grid or load changes in the Microgrid. The reference frequency is provided by the unity during the grid-connected

mode, while in the islanded mode, a controllable load is used to provide the frequency reference. The following figures demonstrate the simulation results. In the beginning the diesel generator experiences a starting period, but after about one second the system arrives at stable status.

#### Microgrid with Non Conventional Sources/ Microsourses

It has been observed that when there are non conventional sources/microsourses are present then the Active and Reactive powers at Bus 1 are increases with some transient. Diesel Generator is present at Bus 1. Therefore the average active and reactive powers are as follows:

**At variable load  $R=100\Omega$  &  $L=0.005H$ ,  $P = 0.07$  pu and  $Q = 0.04$  pu as shown in figure 5.**

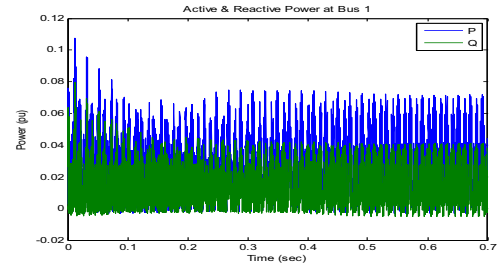

Figure 5 Active Power & Reactive Power at Bus 1

**When variable load changes  $R=50\Omega$  &  $L=0.002H$ , average Active power & Reactive power,  $P = 0.14$  pu and  $Q = 0.07$  pu as shown in figure 6.**

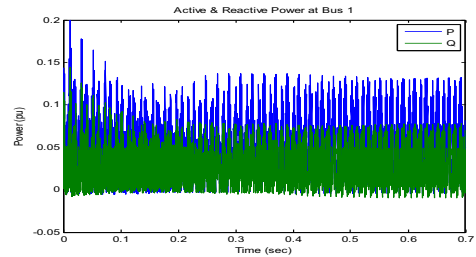

Figure 6 Active Power & Reactive Power at Bus 1

It has been observed that when there are non conventional/microsourses sources are present then the Active and Reactive powers at Bus 2 are increases with some transient. Wind Turbine Generator is present. Therefore the average active and reactive powers are as follows:

**$P = 12$  pu &  $Q = 17$  pu as shown in figure 7**

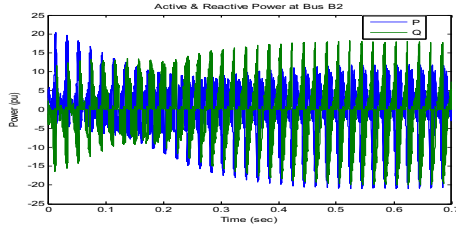

Figure 7 Active Power & Reactive Power at Bus 2

### **Grid is disconnected from Microgrid**

When the grid is connected the powers  $P = 1.2$  pu &  $Q = 1$  pu approx. but when fault occurs at  $t = 0.2$  and clear at  $t = 0.3$  after that the value of both powers get decreases to 0.1 pu. As shown in figure 8

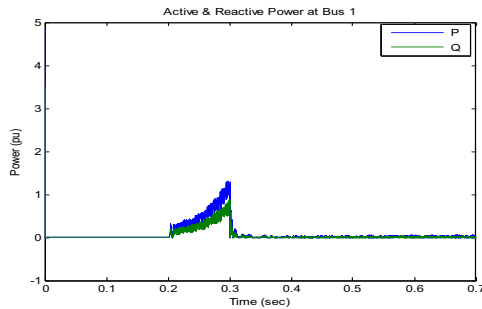

Figure 8 Active & Reactive Power at Bus 1

At time  $t = 0.2$  to  $t = 0.3$  the transient behavior shows in figure 9 due to the fault takes place. The values of Active & reactive powers are large as compared to rest of the time.

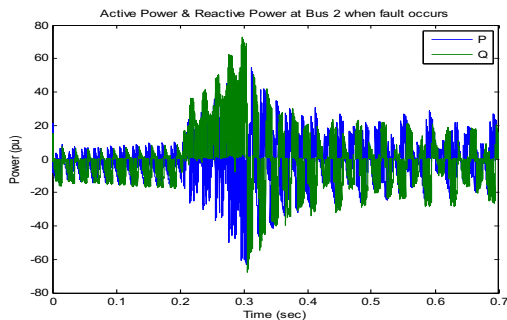

Figure 9 Active & Reactive Power at Bus 2

## **V. CONCLUSIONS**

Microgrid is a well known concept with growing interest in arena of power generation now days. It is the solution for the difficult problems without disrupting the operation of the utility network. The Microgrid concept assumes a cluster of loads and micro sources operating as a single controllable system that provides both power and heat to a local area, for which some forms of energy storage equipments are usually

required. Non convention energy sources are cheap & renewable.

A dynamic model including different microsourses/ non conventional energy sources has been established for the Microgrid system. The dynamic performance of the Microgrid is studied with various disturbances. The Modelling & Simulation of a Microgrid to account for both the transient & steady-state system characteristics is studied. The simulation result shows the dynamic behavior of micro-grids during either grid is connected or islanded. The characteristics is observes for various disturbances such as change of loads and speed of wind turbine generator. The diesel generator is used to compensate the disturbances. By using non conventional energy sources the operating cost is less to fulfill the desired condition in case of grid failure with more efficiency. It concludes that there are increases in power generation when the microsourses/ non conventional energy sources connected within Microgrid which helps in different applications. It also found that when the Grid is disconnected and the power is supplied to the load due to the Microgrid where the microsourses/ non conventional energy sources are connected.

## **VI REFERENCES**

- [1] Lasseter B. Microgrids (Distributed power generation). Power Engineering Society Winter Meeting, IEEE 2001:146-149.
- [2] "Modelling & Simulation of the Microsources Within a Microgrid"- Duan Yubing, Gong Yulei, Li Qingmin, Wang Hui, School of Electrical Engineering, Shandong University, Jinan 250061, China, IEEE 2007.2667-2671.
- [3] B. Kuang, Y. wang and Y. L. Tan, "An  $H_{\infty}$  controller design for diesel engine systems. Power system Technology," International Conference Proceedings, 2000, 1:61-66.
- [4] Y. Zhu, K. Thomsovic, "Development of models for analyzing load-following performance of microturbines and fuel cells". Electric Power Systems Research, 2002, 62(1):1-11.
- [5] S. Roy, O. Malik and G. Hope, "An adaptive control scheme for speed control of diesel driven power-plants". IEEE Transactions on Energy conversion, 1991, 6(4): 605-611.
- [6] S. Roy, O. Malik and G. Hope, "A k-step predictive scheme for speed control of diesel driven power plants," IEEE Transactions on Industry Applications, Vol.6, No.4, 1991.
- [7] G. Stavkakis, G. Kariniotakis, "A general simulation algorithm for the accurate assessment of isolated diesel-wind turbines systems-part I: a general multimachine power system model." IEEE Transaction on energy conversion, 1995, 10(3): 577-583.

- [8] N. Hatziargyiou, H. Asano, R. Iravani, and C. Marnay, "Microgrid- An overview of ongoing research, development, and demonstration projects," IEEE Power & Energy Magazine, 2007.
- [9] L. Dignard-Bailey, T. El-Fouly, B. Cullen and M. Wrinch, H. Farhangi, J. Peralta – "Canada Overview Microgrid Research and Applications," San Diego 2009 Symposium on Microgrids
- [10] Martin Kanálik, František Lizák, "Possibilities of Distributed Generation Simulations Using by MATLAB" 51707-IC-1-2005-1-CZ-ERASMUS-IPUC-3.