

SmartPorter: A Combined Perishable Food and People Transport Architecture in Smart Urban Areas

Amitangshu Pal and Krishna Kant

Computer and Information Sciences, Temple University, Philadelphia, PA 19122

E-mail:{amitangshu.pal, kkant}@temple.edu

Abstract- The current bulk transit systems (e.g., buses) and local perishable food distribution logistics, both suffer from significant fuel inefficiency along with food wastage due to quality degradation in the distribution pipeline. In this paper we present a mechanism that exploits automated electric vehicles (AEVs) in future smart cities and regions to provide both people transport and fresh food distribution that minimizes empty miles of the vehicles (and thus enhances transport efficiency) while meeting the constraints on passenger transit time and food freshness. We devise an optimization framework and show how it can be solved using genetic algorithms in order to handle dynamic demands for passenger transport/products, uncertain supply delays, and variations in product availability. Performance evaluations with extensive simulations show that flexibly deciding the AEV routes improves the transportation efficiency by $\sim 24\text{-}78\%$ whereas improves the delivery quality by ~ 2 times compared to the typical fixed routes/schedules used both by regular passenger bus services and by local distribution operations.

I. INTRODUCTION

Today's distribution and transport logistics suffer from significant inefficiency factors mainly due to lack of resource and infrastructure sharing. According to some recent studies, the current transportation efficiency is in the neighborhood of 10% [1]. In the traditional commodity supply chain delivering fresh food, trucks often go either empty (to return the truck and/or driver to their home location) or partially empty (due to unavailability of suitable product or perishability concerns of the carried food). This leads to largely avoidable distribution costs, transportation carbon footprint, road congestion, delivery delays, etc. Yet, a significant percentage of fresh food is wasted due to real or perceived spoilage or loss of quality of fresh food from farm to the end customer. This paper exploits the ongoing technological developments to devise a combined mechanism for both distributing perishable food and transporting people in the context of smart urban areas.

One major obstruction to improving efficiency and decreasing food waste is the lack of universal sharing of logistics, particularly among the large vendors. However, the improving technology and the pressures to reduce cost are resulting to rapid growth of 3rd party logistics (3PL) and its derivatives such as 4PL which already account for more than 54% of the distribution logistics. 3PL involves outsourced logistics services using shared resources (warehouses, trucks, drivers, loading/unloading equipment etc.) and can achieve significant savings. Yet another development of note is the emergence of autonomous vehicles that can transform the logistics by removing the most difficult of the logistics restrictions: need to find drivers, ensure that they do not drive for more than the safe period, and get them home most nights.

This research was supported by the NSF grant CNS-1542839.

In this paper, we take this a step further and consider autonomous electric vehicles (AEVs) for logistics to further reduce the carbon footprint of product distribution. We specifically focus on perishable commodities in a large urban region, where the distribution must be driven by the perishability processes so that the product waste can be minimized. Unlike long distance perishable product logistics where proper refrigeration facilities are essential, the regional logistics considered here can reduce the distribution costs substantially and (lower carbon footprint) if the distribution can be sufficiently agile such that refrigeration facilities can be either eliminated or reduced substantially. Another challenge in local logistics for fresh food is that the quantities produced are not large enough to fill large trucks, and we must consider smaller vehicles and sharing of space between multiple products with differing perishability processes. As the trends of grow local, buy local, and urban agriculture take hold, we expect the variety of products to increase and quantities of any given products to be transported to go down.

TABLE I. COMPARISON OF CO₂ EMISSIONS; BUS TRANSIT VS PASSENGER CARS [2]

	Num of commuters	Passenger miles/gallon	Pounds CO ₂ /100 passenger miles
Passenger car (25 mpg)	1	25.0	89
Heavy-duty transit bus (2.33 mpg)	1	2.3	953
	5	11.7	191
	11	25.6	87
	40	93.2	24
	70	163.1	14

The city bus services suffer similar level of inefficiency factors; in many regions buses with capacities of 50-100 have occupancy of just 2-3 [3]. Because of such empty miles mass transit vehicles use up roughly the same energy and emissions (shown in Table. I) whether they are full or empty, and for much of the time, they're more empty than full [4]. As a result, while systems in major cities like New York's have a low per-passenger carbon rate, those in Cleveland, Pittsburgh, and Memphis have a comparatively high one [2]. The efficiency factor can be improved easily by abandoning low-density routes and running the remaining lines at peak hours. However many metro areas choose to design systems that favor *coverage* over capacity, knowing full well that will mean running some empty buses, because suburban or low-income residents need them [2]. This results in a competing goals of transportation efficiency and coverage, which cannot be fulfilled simultaneously by implementing regular bus services with standard bus routes. A win-win situation is only possible if the bus services can be *on demand* where a passenger first requests or reserves a ride and requirements from his mobile phone, and then in about 15-20 minutes, an AEV pulls up

in front of his nearest pickup location point. These AEVs will pick up and drop off multiple passengers on their way, which makes them different than typical taxi services. The key challenge is to schedule and update the AEVs and their routes depending on the passenger's demands while ensuring the dual contradictory objectives of efficiency and coverage.

Even without the driver, the proper spatial distribution of delivery vehicles and containers remains an important aspect of logistics and transportation; therefore, we envision each AEV visiting a number of pickup/delivery points and then return to their starting points before running out of energy for further recharging. To improve the transportation efficiency further, we merge people transportation along with the food distribution logistics. A shared use of AEVs for carrying both products and passengers can maintain desired transport efficiency in the face of both longer term changes and short term fluctuations in product availability and demand in smart urban areas. Carriers delivering food packages can give ride to the passengers if their destination points are on the way of the carriers. Some of the recent initiatives have been taken by Sidecar in San Francisco [5], [6] shows that this combined procedure can cut the shipping cost by 1/5 while reducing the delivery time by half as the carriers are better utilized and busier for longer periods of time. This is thus a win-win situation where the carriers earn 75% more while the people and packages experience lower waiting time and prices due to more and quick availability of the carriers.

This promising combination of people transportation and food delivery needs to fulfill the delivery guarantees of both the packages and the passengers, which is the main objective of this paper. We propose a collaborative urban transportation architecture called SmartPorter where the AEVs collaboratively meet the demands to maximize the transportation efficiency while meeting the delivery demands. We develop the integrated framework of SmartPorter architecture and evaluate the tradeoffs in between different design objectives. Through simulations we show that SmartPorter improves the transportation efficiency by $\sim 24-78\%$, whereas improves the delivery quality by ~ 2 times compared to the typical fixed route bus services or food delivery services by utilizing the AEV space efficiently while satisfying the distribution demands.

The outline of this paper is as follows. Section II discusses the motivation and objectives of the proposed combined architecture. Section III then introduces the SmartPorter architecture along with the AEV route planing and adaptation. In section IV we develop an analytical framework to model different design tradeoffs. Section V summarizes the related works and literatures. Finally, section VI concludes the discussion.

II. MOTIVATION, OBJECTIVES AND PRELIMINARIES

Current supply chain logistics face a great deal of inefficiency as most of the carriers go often half empty at departure. Some recent studies show that in USA trailers are often 60% full, whereas the global transportation efficiency is even lower than 10% [1]. The primary reason for this inefficiency is the lack of sharing and coordination among the distribution facilities, as most retailers use their private logistics for conveying their packages within their own network that results in significant empty miles. Shared logistics have the potential

to improve the logistics efficiency by reducing empty miles. On the sharing front, large operators (e.g., Walmart, Boeing, etc.) continue to have their private logistics networks, but smaller ones are rapidly moving towards *outsourced services*, provided by third parties. The so called third party logistics (3PL) (and its derivatives such as 4PL) allow the supply chain facilities to be shared among multiple customers. Recent data suggests that 54% of transportation and 39% of warehouse operations are outsourced [7]. Effective sharing is key to reducing cost, energy consumption, and environmental impact, but is significantly difficult due to several factors. In particular, logistics must worry about such things as transport carriers (e.g., trucks), product containers etc. It is clear that there is a huge scope for enhancing logistics efficiency and hence its environmental impact.

On the other hand in people transportation, city buses suffers similar inefficiency factors as most of them run almost empty especially at off-hours. According to a recent article [4] "*For the bulk of the day, and on quieter routes, the average city bus usually undoes whatever efficiencies are gained during the few hours a day, on the few routes, where transit is at its peak*". On the other hand passengers are generally reluctant to rent a taxi due to high fare rates and low cab availability especially at the time of rush hours. At the same time buses generally go in specific routes which significantly limit their usefulness in passenger transportation. According to some recent studies [8], [9] the average taxi fare of New York is 5.8 times higher than the average public transport, whereas in countries like China it is ~ 11 times. On the other hand in rush hours the cabs are 80% occupied which results in long waiting time of the passengers. Several recent studies [10] have shown that the passenger frequency goes up significantly during the weekends (from Friday to Sunday) and also in rush hours, thus the bus frequency needs to be enhanced at the rush hours for better passenger service. On the other hand at the off-hours running regular bus services will result in significant decrease in efficiency. Thus there is a significant potential of developing an *adaptive and flexible bus service* depending on the passenger's needs rather than a fixed and regular bus service, to significantly improve the efficiency while reducing the environmental footprint.

Other than efficiency, another important characteristics of food logistics is spoilage or perishability. Food products often deteriorate in quality or in value/usefulness as a function of flow time through the logistics system. The deterioration as a function of time t can be described by a non-decreasing function that we henceforth denote as $\zeta(t)$. In general, $\zeta(t)$ is linear for fruits or vegetables and exponential for fish/meat. The decay itself is a complex phenomenon and could refer to many aspects, including those that can be directly detected by the customers (e.g., color, texture, firmness, taste, etc.) and those that are latent but perhaps even more important, such as degradation of vitamin content or growth of bacteria. Furthermore, the decay rate is strongly influenced by the environmental parameters such as temperature, humidity, vibration etc. In passenger transportation there is no direct notion of perishability, however passengers satisfaction level decreases as their waiting time increases. Infact passengers generally like to reach at their destination within some specified time, in such cases we can model the corresponding perishability function as a step-function.

In this paper we extend the concepts of space sharing in distribution networks. The conceptual framework is applicable to supply chain logistics for food transportation, flexible bus services for passenger transportation, or can be a combined transportation of both by vehicles like brucks. Conceptually it is the scheduling of AEVs to determine the most efficient way to pickup and deliver the passengers or packages using smart sharing, while meeting their delivery requirements. In general we define the passengers or packages as different types of *objects* that needs to be transported depending on their requirements. The pickup and dropoff locations are defined as *distribution points (DPs)*. We assume that the AEVs are *convertible* with folding seats and can divide the space among the passengers and packages dynamically by expanding and shrinking the two boundaries. Such reconfigurable car space utilization is available in few vehicles [11] but mainly for improving the user comfort labels. However with some engineering modifications, the space can be shared in between the passengers and packages too. Infact a number of customers who shop at the retail stores (Walmart, Target etc.) and use public transport can be highly benefited if such service is available. We also assume that the AEVs are equipped with GPS that periodically update their location in a centralized location.

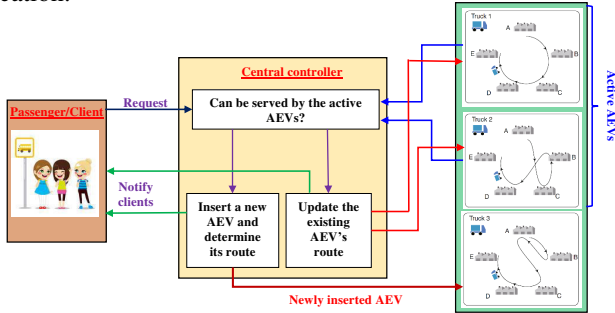

Fig. 1. A schematic of our proposed overall SmartPorter architecture.

III. SMARTPORTER ARCHITECTURE

We next present the overview of the SmartPorter architecture using Fig. 1. Assume that D is the set of depots where the AEVs wait for the instructions from the control center. Upon getting the route instructions from the control center, the AEVs start their journey and return to their corresponding depot after loading-unloading subsequent objects. Thus the trip time of the AEVs are limited by their battery capacity within which they need to return to their depots. We believe that this assumption is equally valid for manually driven vehicles as the drivers need to return home after their driving hours, which limits the trip length of their vehicles. However in case of drivers the resting time is longer and inflexible whereas in case of AEVs, the old batteries can be replaced with the charged ones in just few minutes. The purpose of returning the AEVs to the depots is to maintain proper spatial distribution of the AEVs across the depots. The SmartPorter clients first request the controlling center regarding their delivery requirements and details, i.e. the source and destination locations, types and amount of objects to be carried along with their delivery deadlines or freshness qualities etc. A centralized controller then calculates the AEV's routes along with their loading-unloading schedules to meet the client requests. When new requests arrive, the controller first tries to modify/perturb the routes of the already active AEVs rather than dispatching a new AEV from the depot, as far as the new route does not disturb the delivery requirements of the

already loaded or reserved objects. On the other hand if the new requests cannot be served by the existing active AEVs, new AEVs are inserted into the system. Below we describe the entire procedure in two subsections: initial trip planing of the AEVs and the perturbation of the already active AEVs.

A. Initial trip planing of the AEVs

With these we next formulate our AEV scheduling problem with the vision of sharing the AEV space to deliver objects among multiple distribution points. Each AEV maintains it's maximum continuous driving time and within that time it tries to serve as many orders as he can to maximize the transportation efficiency. This AEV routing strategy is similar to the *traveling salesman problem (TSP)* [12], *pickup and delivery problem* [13] and *ride-sharing problem* [14], but has a number of differences. First, most of the schemes proposed for the above-mentioned problems try to minimize the overall travel time of the vehicles, whereas our objective is to maximize the fuel-efficiency, reduce the empty-miles and at the same time meet the package deadlines and requirements. Second the above-mentioned problems do not have any maximum delay bound, whereas our scheme has to consider the maximum driving time of an AEV, which puts an upper limit of their travel times. Third in the above related problems, a vehicle needs to go to every location at least once and serves their requirements, whereas in our scheme an AEV may skip fulfilling the demands of some clients within its coverage area, if the maximum time-limit cannot be maintained or if visiting certain clients effectively reduce the performance objectives. Those skipped objects will be delivered by other AEVs. We next model the optimization problem and then discuss the complexity of AEV route planning as follows.

TABLE II. TABLE OF NOTATIONS

		Indices
i, j	\triangleq	Index for distribution centers (1, ..., \mathfrak{N}) that are within the coverage areas of the AEVs
ℓ	\triangleq	Index for transit-segments of the AEVs (1, ..., \mathfrak{T})
t	\triangleq	Index for types of objects (1, ..., \mathcal{T})
		Transportation variables
$p_{ij}^{t\ell}$	\triangleq	Amount of type t loaded at DP_i for delivery at DP_j at the ℓ -th transit-segment
$d_{ij}^{t\ell}$	\triangleq	Amount of type t unloaded at DP_i from DP_j at the ℓ -th transit-segment
$R_{ij}^{t\ell}$	\triangleq	Amount of type t that are on the AEV for delivery at DP_i from DP_j at the ℓ -th transit-segment
$L^{t\ell}$	\triangleq	AEV load of type t at transit-segment ℓ
S_{ij}^t	\triangleq	Delivery request from DP_i to DP_j of type t
T_{ij}	\triangleq	Time of travel from DP_i to DP_j
B_j^ℓ	\triangleq	Time when the AEV delivers at DP_j in the ℓ -th transit-segment
		Decision Variables
$x_{ij}^\ell \in 0, 1$	\triangleq	Whether or not the AEV goes from DP_i to DP_j at the ℓ -th transit-segment

The objective of an AEV scheduling is to maximize the efficiency of the transportation, which we define as the amount of product delivery per miles/time. Thus our objective function is to

$$\text{Maximize } \frac{\sum_i \sum_j \sum_t \sum_\ell d_{ij}^{t\ell}}{\sum_i \sum_j \sum_\ell x_{ij}^\ell \cdot T_{ij}} \quad (1)$$

The necessary variables are listed in Table II, where the term *transit-segment* is defined as follows. The objective

function is defined as *efficiency factor*. If a AEV goes from $DP_1 \rightarrow DP_2 \rightarrow DP_3 \rightarrow DP_1$, then the first transit-trip segment starts at DP_1 and ends at DP_2 , the second segment starts at DP_2 and ends at DP_3 and so on. The maximum number of transit-segments allowed for a AEV is assumed to be \mathfrak{T} . The source of an AEV is denoted as \textcircled{S} . The constraints are defined as follows.

Continuity constraint: If the AEV comes at point j at transit-segment ℓ , then it needs to leave from j at transit-segment $\ell+1$, i.e.

$$\sum_i x_{ij}^\ell = \sum_k x_{jk}^{\ell+1} \quad \forall j, \forall \ell \in \{1, 2, \dots, \mathfrak{T} - 1\} \quad (2)$$

Also an AEV loads and unloads objects at DP_i only when it is at the DP_i , i.e.

$$\sum_j \sum_t d_{ij}^{t(\ell+1)} \leq \mathbb{M} \sum_k x_{ki}^\ell \quad (3)$$

$$\sum_j \sum_t p_{ij}^{t(\ell+1)} \leq \mathbb{M} \sum_k x_{ki}^\ell \quad \forall i, \forall \ell \in \{1, 2, \dots, \mathfrak{T} - 1\} \quad (4)$$

where \mathbb{M} is at least as high as the maximum amount of objects that can be picked-up/delivered at any particular DP. The amount of objects that is loaded is less than the corresponding delivery requests as summarized in equation(5). Also the cumulative amount of loading and unloading is equal which is shown in equation(6). Equations(7)-(9) show that the AEVs need to deliver all the objects that they have loaded before ending their journey.

$$\sum_\ell p_{ij}^{t\ell} \leq S_{ij}^t \quad \forall i, \forall j, \forall t \quad (5)$$

$$\sum_\ell d_{ij}^{t\ell} = \sum_\ell p_{ji}^{t\ell} \quad \forall i, \forall j, \forall t \quad (6)$$

$$R_{ji}^{t\ell} = R_{ji}^{t(\ell-1)} + p_{ji}^{t\ell} - d_{ij}^{t\ell} \quad \forall i, \forall j, \forall \ell, \forall t \quad (7)$$

$$d_{ij}^{t\ell} = R_{ji}^{t(\ell-1)} \times \sum_k x_{ki}^{\ell-1} \quad \forall i, \forall j, \forall \ell \in \{1, 2, \dots, \mathfrak{T} - 1\}, \forall t \quad (8)$$

$$R_{ji}^{t\mathfrak{T}} = 0 \quad \forall i, \forall j, \forall \ell, \forall t \quad (9)$$

AEV-load constraint: Constraint(11) shows that the AEV-load at any transit-segment ℓ is equal to the AEV-load at its previous transit-segment and the difference of the amount that is loaded and unloaded at ℓ . Also the AEV-load at any ℓ is less than the AEV capacity C , which is shown in equation(12).

$$L^{t1} = \sum_i p_{\textcircled{S}i}^{t1} \quad (10)$$

$$L^{t\ell} = L^{t(\ell-1)} + \sum_i \sum_j (p_{ij}^{t\ell} - d_{ij}^{t\ell}) \quad \forall \ell \in \{2, \dots, \mathfrak{T}\}, \forall t \quad (11)$$

$$\sum_t L^{t\ell} \cdot \mathcal{V}^t \leq C \quad \forall \ell \in \{2, \dots, \mathfrak{T}\} \quad (12)$$

where \mathcal{V}^t is the volume of the container (object) type t . In case of food logistics, constraint(12) simply assumes that multiple containers of different sizes always fit within a AEV as far as their cumulative volume is less than the AEV's capacity. This is an over-estimation of the packing ability of the containers. However in reality this over-estimated amount of objects can

TABLE III. ORDER MATRIX

	A	B	C	D	E
A	-	X	X	X	X
B	-	-	X	-	-
C	X	-	-	-	X
D	X	-	-	-	X
E	X	-	X	X	-

TABLE IV. TIME MATRIX

	A	B	C	D	E
A	-	2	3	3	3
B	2	-	2	3	3
C	3	2	-	1	1.5
D	3	3	1	-	1
E	3	3	1.5	1	-

be passed to a *loading module* that loads a fraction of the assigned objects by solving typical 3D-bin packing [15]. The remaining objects can be carried by other AEVs while they are scheduled. Notice that due to the use of modular containers or π -containers [1], the error due to this over-estimation is limited.

Travel time constraint: The total travel time is bounded by the minimum and maximum driving time allowed, i.e.

$$T_{\min} \leq \sum_i \sum_j \sum_t x_{ij}^\ell \cdot T_{ij} \leq T_{\max} \quad (13)$$

Also the delivery time at the DPs are recorded as follows:

$$B_{\textcircled{S}}^1 = 0 \quad (14)$$

$$B_j^\ell = \sum_i x_{ij}^{\ell-1} \times (B_i^{\ell-1} + T_{ij} + w_j) \quad \forall j, \forall \ell \in \{2, \dots, \mathfrak{T} - 1\} \quad (15)$$

where w_j is assumed be the time for pickup/delivery at the delivery point j .

Delivery constraint: The delivered objects should ensure its required freshness limit \mathfrak{S} , i.e.

$$(\mathbb{Q}_{ij}^t - k^t \cdot B_j^\ell) d_{ji}^{t\ell} \geq \mathfrak{S} \cdot d_{ji}^{t\ell} \quad \forall i, \forall j, \forall \ell, \forall t \quad (16)$$

This constraint assume linear decay, whereas exponential decay can be modeled in a similar fashion. Such delivery constraint effectively models a delivery deadlines corresponding to different types of objects.

Other constraints: Also the AEV should start and end at the starting point. To keep the problem simple, we assume that the AEV does not visit a point more than η times. For our simulations, we keep η to be 1 for simplicity. These give rise to the following constraints

$$\begin{aligned} \sum_i \sum_\ell x_{\textcircled{S}i}^\ell + \sum_j \sum_\ell x_{j\textcircled{S}}^\ell &= 2 \\ \sum_i \sum_\ell x_{ij}^\ell &\leq \eta \quad \forall j \text{ other than the source} \\ \sum_i \sum_j x_{ij}^\ell &\leq 1 \quad \forall t & \sum_i x_{\textcircled{S}i}^1 &= 1 \\ \sum_j \sum_\ell x_{j\textcircled{S}}^\ell &= 1 & \sum_j \sum_{\ell=2}^{\mathfrak{T}} x_{\textcircled{S}j}^\ell &= 0 \end{aligned} \quad (17)$$

Genetic Algorithm Based Metaheuristics: The above mentioned optimization problem can be proven to be NP-hard [16], we thus propose a genetic algorithm based metaheuristic to solve this problem. Genetic algorithms are probabilistic techniques that mimic the natural evolutionary process. A genetic algorithm maintains a population of candidate solutions. Each candidate solution in the population is encoded into a structure called the *chromosome*. Each chromosome is assigned a *fitness value*, which represents the quality of the candidate solution. A selection process simulates the *survival of the fittest*

paradigm from nature. Better-fitted chromosomes have higher chances of surviving to the next generation. The number of chromosome per generation is constant. As in natural life, offspring chromosomes are obtained from parent chromosomes mainly by using two operators, crossover and mutation. Some other chromosomes simply survive unaltered, while others die off.

We first assume that there are n distribution points. An AEV needs to visit at all the points to pickup and drop off necessary objects and then come back to its starting point. Let us define a chromosome as a vector (c_1, c_2, \dots, c_n) , where c_i represents the i -th distribution point. We assume that there are M chromosomes in a mating pool. The *fitness value* of each chromosome is the overall transportation efficiency given by the objective function of the optimization problem. To calculate the fitness value we need to determine the amount of objects that are loaded and unloaded at different points. For a given chromosome vector we decide the loading-unloading amount as follows: at point i , assume that there are a_{ij}^t amount of objects for destination j of type t . It then calculates the transportation efficiency of carrying that objects as $e_{ij} = \frac{\sum_t a_{ij}^t}{d_{i \rightarrow j}}$ $\forall j = i + 1, \dots, n$ where $d_{i \rightarrow j}$ is the distance from i to j through the router vector (c_1, c_2, \dots, c_n) . It then sorts the e_{ij} in decreasing order and load the objects in that order until (a) the AEVs are fully loaded, or (b) all objects from i are loaded. For different types of objects, the higher priority objects are loaded ahead of the low priority objects.

Initially the mating pool is generated randomly. We adopt the well known *elitism* selection mechanism where $M_e < M$ best chromosomes are placed directly in the next generation. The rest of the $M - M_e$ chromosomes are generated by mutating the elite chromosomes. Chromosomes that do not satisfy constraints (13) and (16) are discarded from the pool. The algorithm stops when the best solution does not improve significantly for a fixed number of consecutive iterations or a large predefined number of iterations is reached. When the stopping criterion is reached, the algorithm chooses the chromosome/solution with the highest fitness value. This process is repeated for all $n = 2, \dots, N$ and from the depots as the starting points. The best possible solution is then used to schedule the AEV to load-unload the corresponding objects. In this way the AEVs are dispatched one by one until all the demands are satisfied.

We first compare the effectiveness of the proposed genetic algorithm compared to the optimal solution in Fig. 2. We use AMPL solver [17] for solving the optimization problem. The travel time in between the DPs are shown in Table IV. The demand matrix of the objects among the DPs are shown in Table III. In Table III X is a variable, which is varied from 10 to 200 for our simulations. We

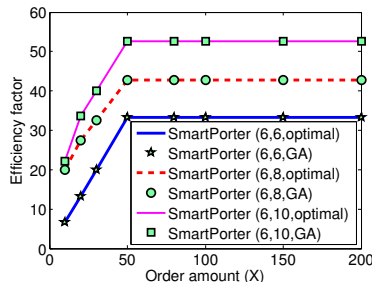

Fig. 2. Validation of the proposed genetic algorithm (GA) compared to the optimal solution. Within first braces the first and second indexes are T_{\min} and T_{\max} respectively.

assume all the objects are of same size of unit volume. The AEV has a volume of 100, i.e. its capacity limit of 100 objects. Also the T_{\min} is assumed to be 6 units, whereas T_{\max} is varied in between 6 to 10 units. We ignore the pickup/delivery time for simplicity. The mating pool size M is assumed to be 100. From Fig. 2 we can observe that the proposed genetic algorithm closely matches with the outcome of the developed optimization problem. We thus use the genetic algorithm to generate the results for our simulations.

B. Perturb the routes of existing active AEVs

In real scenarios the delivery orders from the source-destination points come continuously and thus the AEVs need to change their routes and delivery schedules to pickup some new customers if the delivery requirements of the already reserved objects are not violated. We notice that the AEVs need to check four conditions before deciding to perturb their routes or delivery schedules of the AEVs.

Delivery order: In an AEV's travel route the source point needs to be visited ahead of the corresponding destination points. If we assume the points of an AEV's trip as a set of states, then a AEV's route $\phi \models s_i \rightarrow \mathbf{F}d_i$, for the source-destination pairs (s_i, d_i) where \models denotes satisfaction relation, \rightarrow denotes implication, and \mathbf{F} is the forward operator.

Delivery time: The delivery time of the already reserved objects and the new objects need to be met. Thus for the destination points d_i , the AEV trip $\phi \models_{t_i} \mathbf{F}d_i$, where t_i is the delivery deadline for the objects destined to d_i .

Capacity constraint: The AEVs should not run out of space for detouring and loading some new objects that will disturb their already confirmed objects.

Travel time: The travel time of an AEV cannot exceed its maximum amount, otherwise it will run out of charge. Thus if a is the starting point of an AEV, then $\phi \models_{T_{\max}} \mathbf{F}a$.

We call these conditions OTCT (order, time, capacity, travel time) conditions, which need to be satisfied whenever the AEVs change their travel plan. To satisfy these online requests we run the genetic algorithm along with the additional OTCT constraints to check whether the existing running AEVs can fulfill the requests of the online requests. If the requests cannot be satisfied by the running AEVs, the new AEVs are inserted into the system whose route is planned according to section III-A.

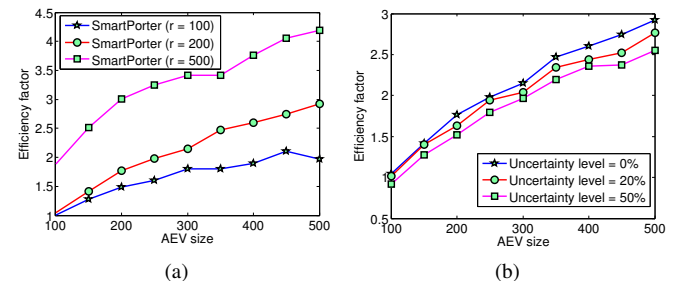

Fig. 3. Variation of efficiency factor with (a) different demand rates, and (b) level of uncertainty of supplies.

C. Performance evaluation:

We simulate the performance of our proposed SmartPorter system in Matlab R2015b [18]. We distribute 50 nodes uniformly in an area of 100×100 sq. unit. We assume four

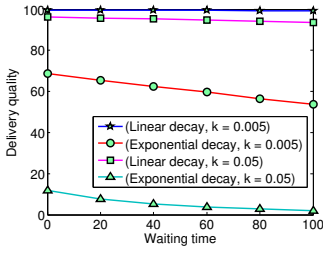

Fig. 4. Effect of package waiting time on delivery quality.

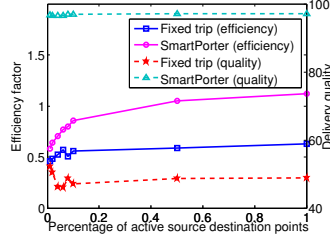

Fig. 5. Comparison with fixed trip routes.

depots that are the starting and finishing points of the AEVs. The source-destination pairs are generated uniformly randomly with a probability of 10%. Each source-destination pair has to ship some objects that are uniformly generated from $(0, r)$. We assume two types of objects, one has higher priority than the other one. T_{\min} and T_{\max} are assumed to be of 50 units and 500 units respectively. We assume that the deadline of the both objects to be 500 units, which is identical to the value of the chosen T_{\max} .

Comparison with different AEV size: Fig. 3(a) shows the achieved transportation efficiency with the variation in AEV size. From Fig. 3(a) we can observe that the SmartPorter system improves the transportation efficiency by ~ 2 times with the increase in r from 100 to 500. This is because with more package arrival, the AEV space is better utilized which improves the transportation efficiency and reduces the empty miles. The efficiency also increases by ~ 2 times while the AEV size increases from 100 to 500 as the AEVs can transport more objects in their journey.

The efficiency factor is also affected if the arrival of objects are not certain or delayed, which is depicted in Fig. 3(b). In Fig. 3(b) the “uncertainty level” is defined as the probability with which the arrival of products are reduced by some fraction (assumed to be 80%) of the promised amount. From this figure we can observe that the efficiency decays with the increase in the level of uncertainty which is obvious due to lesser availability.

Effects of item waiting time on delivery quality: We now show the effect of object waiting time on delivery quality. We assume that the objects wait at the distribution points before an AEV arrives, picks them up and delivers them in their successive destinations. This entire delay results in quality loss or spoilage which we model as linear and exponential function with spoilage rate k of 0.005 and 0.05 per unit time respectively. A fresh item is assumed to have a quality of 100. Fig. 4 shows the variation of delivery quality with different item waiting time and spoilage rates. From this figure we can observe that the delivery quality drops drastically with exponential decay model, with $k = 0.005$ and 0.05 the delivery quality drops down by $\sim 40\%$ and $< 5\%$ respectively when the waiting time becomes 100 units. Intuitively this motivates the necessity of just-in-time supply of objects with respect to the AEV arrival time at the distribution points, rather than keeping the objects waiting for longer periods.

Comparison with fixed AEV trips: We next compare the effectiveness of SmartPorter in comparison to fixed AEV routes that are generally applicable to typical bus services in Fig. 5. We first generate four fixed travel routes from four depots for

the AEVs using [19]. We next model different request arrival rates in between the source-destination distribution points of the travel routes. In Fig. 5 the x-axis is the percentage of the total source-destination distribution points from where requests arrive. From Fig. 5 we can observe that compared to the fixed trip scheme, SmartPorter improves the efficiency factor by $\sim 24-78\%$ by dynamically choosing the AEV trips. From the food distribution angle, SmartPorter also improves the delivery quality by ~ 2 times by flexibly routing the AEVs in between the source-destination distribution points, where the spoilage process is assumed to be linear with spoilage rate of 0.05 per time unit.

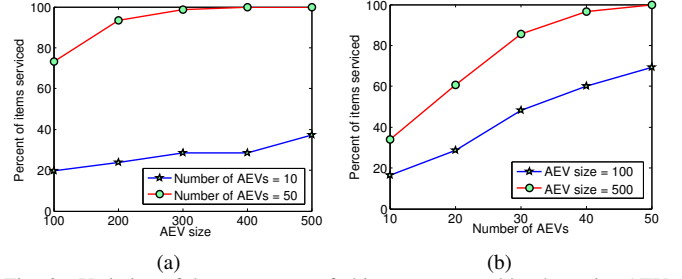

Fig. 6. Variation of the percentage of objects transported by the active AEVs with (a) different AEV sizes, and (b) their number.

Effects of AEV trip perturbation: To observe the performance of the perturbation phase, we first generate the routes of the AEVs, as well as their delivery schedules and requirements among different distribution points. We next randomly generate new delivery requests among different source-destination pairs with a probability of 10%, whereas the amount of objects that are to be transported is chosen uniformly randomly from $(0, r)$. For Fig. 6 we assume $r = 500$. We next implement our AEV route adaptation scheme while maintaining the OTCT conditions as mentioned in section III-B, and calculate the percentage of new objects that can be transported by the existing active AEVs.

Fig. 6 shows the percentage of new objects that are serviced with different AEV sizes and numbers. From Fig. 6 we can observe that the amount of new item serviced increases by $\sim 20\%$ as the AEV size increases from 100 to 500. The objects serviced also increase by $\sim 60\%$ while the number of AEVs increase from 10 to 50. We thus observe that by adapting the active AEV routes, SmartPorter can serve a certain portion ($> 20\%$) of the new requests rather than instructing some new AEVs to serve the requests. Notice that all the new requests may not be served by the existing active AEVs, and thus new AEVs need to be added into the system to serve the rest as mentioned in section III-A.

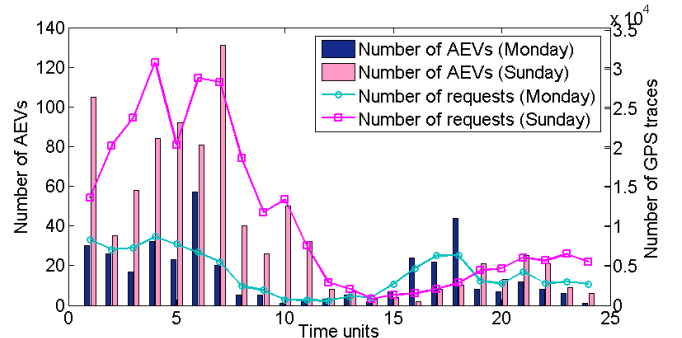

Fig. 7. Number of active AEVs with varying traffic demands.

Comparison with time varying demands: To explore the performance of SmartPorter with time varying orders, we use the data [20] obtained from the mobile apps in Uber cars that were actively transporting passengers in San Francisco. The dataset consists of GPS traces of 25000 pickups/trips by multiple Uber cars for one week; corresponding to each trip the app collects the GPS traces in every 4 seconds. The data have been anonymized by removing names, actual trip start and end points. The actual dates were also substituted, however the weekdays and time of day are still intact [10]. Even though the dataset doesn't contain the actual starting and ending points of individual trips, we may still get a sense of how long the cabs are actively transporting passengers from the "frequency of these GPS points" at different days and hours.

Fig. 7 shows the frequency of GPS traces obtained from the moving cabs of Mondays and Sundays at different hours of the day. We choose these two days as they are representative of the variation in traffic pattern of an office day and a weekend. We can observe that the frequency goes up during the weekend (i.e. Sunday) compared to weekdays and peaks in early hours of the day, which shows that San Francisco has a very active night life. To simulate this traffic pattern in SmartPorter we assume r to be proportional to this varying traffic pattern and simulate this for 24 time units. In Fig. 7 we deploy 10 distribution points uniformly in an area of 100×100 sq. unit. The results are shown in Fig. 7 which shows that the number of AEVs required to fulfill the requests varies in proportional to the frequency of GPS points sent by the cabs at different time units. This shows the adaptive nature of SmartPorter depending on the demand rate, rather than scheduling buses at regular intervals (like 15-20 minutes).

IV. ANALYTICAL MODEL FOR AEV FREQUENCY, EFFICIENCY AND QUALITY TRADEOFF

We next model a simplified analytical model to demonstrate the tradeoff between the transportation efficiency and delivery quality or freshness. Assume that in a DP the objects are coming at a rate of λ packets in unit time, whereas the carrier companies (or shipping companies) are sending their AEVs at f per unit time. Notice that as the AEV frequency becomes higher, the waiting time of the objects at the distribution point decreases, which improves their delivery freshness. Whereas higher AEV frequency results in more empty miles especially when λ is lower.

We next define the delivery quality Q as a function of f . Q may be exponential or linear depending on the perishability characteristics of the objects. For passenger transportation, Q may be thought of a passenger satisfaction function which will decay as the waiting time increases. We assume that the delivery point's utility is proportional to the delivery quality (or satisfaction) of the objects which we denote as $c.Q(f)$, where c is a constant. Also we assume that the delivery point pays ρ units per object (package or passenger) to the carrier company. Thus the profit of the distribution point is $\mathcal{U}_{DP} = \lambda(c.Q(f) - \rho)$.

On the other hand the shipping company's utility or profit is $\mathcal{U}_{SC} = \lambda.\rho - f.s.\tau$, where s and τ are the size of the AEVs in terms of number of objects that it can load and cost per unit capacity respectively. Thus the shipping companies will try to improve their space efficiency by matching f with the object arrival rate λ , whereas the distribution companies will try to

maximize their delivery freshness to improve their profit. Thus the social utility is given by

$$\mathcal{U} = \mathcal{U}_{DP} + \mathcal{U}_{SC} = \lambda.c.Q(f) - f.s.\tau \quad (18)$$

If the spoilage function is assumed to be linear decay with a rate of k , then the optimal AEV frequency, percentage of empty miles (\mathcal{E}) and delivery quality can be written as

$$f_{\text{opt}} = \sqrt{\frac{ck\lambda}{s\tau}} \quad \mathcal{E} = \frac{s.f_{\text{opt}} - \lambda}{s.f_{\text{opt}}} \quad Q_{\text{delivery}} = Q_0 - \frac{k}{f_{\text{opt}}} \quad (19)$$

where Q_0 is assumed to be the initial quality of the objects at the distribution points.

Performance Analysis: Fig. 8(a) shows $\mathcal{U}_{DP}, \mathcal{U}_{SC}, \mathcal{U}$ with different AEV frequency f . For Fig. 8 we assume that $c, s, \tau, \lambda, \rho$ to be 1, 100, 10, 10 and 50 respectively. The initial quality Q_0 and decay rate k is assumed to be 100 and 0.5 respectively. With these set of values f_{opt} is coming to be ~ 0.07 which is also validated from Fig. 8(a). From Fig. 8(a) we can also observe that \mathcal{U}_{DP} starts increasing with the increase in AEV frequency because of faster service of the objects by the AEVs. On the other hand the shipping company's profit starts decreasing *linearly* with increasing f .

Fig. 8(b) shows the optimal AEV frequency f_{opt} with the variation of package arrival rate λ . From Fig. 8(b) we can observe that f_{opt} increases by ~ 3 times when the package arrival rate goes from 0.1 to 1. This is because of the fact that increase in package arrival rate also results in an increase in AEV frequency so avoid long waiting time of the objects at the distribution center. We can also observe that AEV frequency also increases by ~ 1.7 times when the decay rate k varies from 0.25 to 0.75. This is obvious from the fact that more decay rate results in quick spoilage, thus AEV frequency needs to be higher to void unexpected spoilage.

Fig. 8(c) shows the percentage of empty miles \mathcal{E} with different package arrival rate λ . From this figure we can observe that \mathcal{E} decreases by $\sim 44\%$ when λ is increased from 0.1 to 1. With frequent arrival of objects, the AEVs deliver more objects while reducing their empty miles. Notice that the empty miles increase by $\sim 8-27\%$ with the increase in spoilage rate from 0.25 to 0.75. This is because of the fact that increase in spoilage results in the increase in AEV frequency for delivering fresher objects (as seen in Fig. 8(b)), which results in more empty miles.

Fig. 8(d) shows the delivery quality Q_{delivery} of the objects with the increase in λ . Increasing λ from 0.1 to 1 results in quality improvement by $\sim 1.7-5$ times. This is because of the fact that the increase in λ results in an increase in AEV frequency (as seen in Fig. 8(b)), which results in quicker delivery and thus improved delivery quality. The intuition behind this is that with higher λ the social utility maximization scheme requires faster AEV service to reduce the loss due to spoilage (refer to equation(18)). We can also observe that with the increase in decay rate from 0.25 to 0.75, the delivery quality of the objects decrease by $\sim 14-74\%$ due to quicker spoilage.

V. RELATED WORKS

Recent advances in food distribution: Some very recent related works are reported in [1], [21], [22] on physical

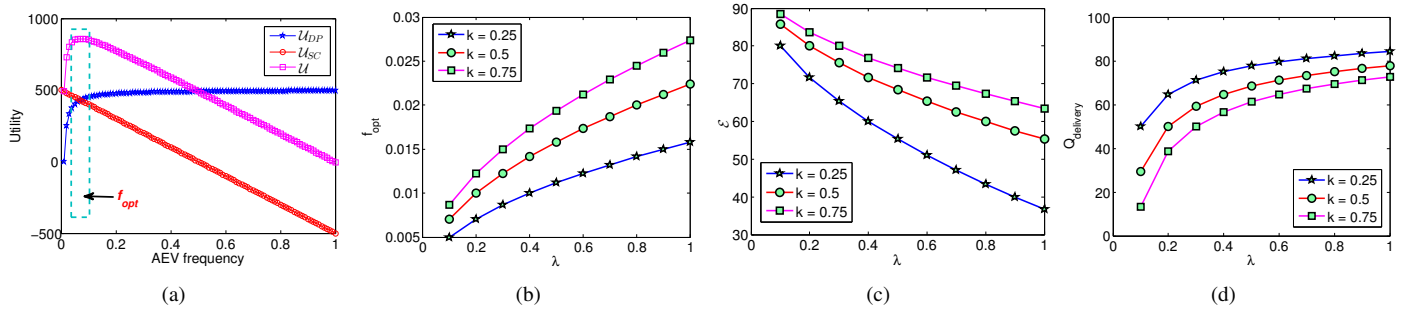

Fig. 8. Variation of (a) different utility functions with AEV frequency. Effect of different package arrival rate λ on (b) optimal AEV frequency f_{opt} , (c) percentage of empty miles \mathcal{E} , and (d) the package delivery quality $\mathcal{Q}_{delivery}$.

Internet, that proposes the idea of imitating the Internet architecture in physical supply chain. In [23], [24], [16] the authors have shown that considerable synergies exist between information networks carrying time-sensitive information and perishable commodity distribution networks, and have proposed a five-layer network model to unify the two. However, these papers talked about some important points regarding reducing empty miles and drivers driving time, standardization of the containers, transportation efficiency, package tracking and traceability etc. while the food quality and freshness have not been discussed.

Taxi recommender and Ridesharing service: Taxi dispatching services [25] send a nearby taxi close to the passengers based on a passenger's call. In [26], [27] the authors propose a system to instruct the driver's to park in certain places so that they can find passengers quickly to maximize profit, based on some historical learning based mechanisms. Such proposals are beneficial for drivers to make quick profit, however the collaborative and shared services are not addressed in these works.

Shared taxicab policies works in limited cities where a cab driver picks up multiple passengers in cheaper cost. Some airport shuttles also provide door-to-door airport shuttle that picks up and drops off multiple passengers [28]. In these cases, route planning are mostly done by the drivers individually or in a small scale ad-hoc manner. In [9] the authors propose a single source multiple destinations ridesharing policy which is mostly applicable in airports or downtown areas where multiple passengers go in the same directions. On the contrary our proposed scheme works in an intelligent and collaborative fashion to improve the overall efficiency of transportation while meeting several delivery requirements of various clients.

VI. CONCLUSIONS

In this paper, we introduced the SmartPorter architecture with the notion of collaborative and adaptive AEV route scheduling and space sharing while improving the transportation efficiency and maintain fresh delivery of packages especially important for perishable food packages. The proposed architecture explored the idea of collaborative logistics and adaptive transportation rather than depending on private logistics and regular, fixed transportation system. SmartPorter system is applicable in several ridesharing environments which includes the combined transportation of perishable food packages of different distribution companies, or the transportation of passengers by exploring flexible bus services, or a combination of two. We believe that the proposed SmartPorter architecture will complement the upcoming smart city planning initiatives

with a vision of smarter and cooperative city logistics and transportation.

REFERENCES

- [1] B.Montreuil, "Toward a physical internet: meeting the global logistics sustainability grand challenge," *Logistics Research*, vol. 3, no. 2-3, pp. 71–87, 2011.
- [2] <http://www.citylab.com/commute/2012/11/can-we-please-stop-pretending-cars-are-greener-transit/3960/>.
- [3] <http://www.zerohedge.com/news/2015-10-31/empty-bus>.
- [4] <http://humantransit.org/2009/12/yet-another-transit-isnt-green-because-of-empty-buses-story.html>.
- [5] <https://www.side.cr/people-packages-the-future-of-same-day-delivery/>.
- [6] <http://digiday.com/brands/uber-combine-ride-sharing-delivery-services/>.
- [7] R.Leuschner *et al.*, "Third-party logistics: A meta-analytic review and investigation of its impact on performance," *Journal of Supply Chain Management*, vol. 50, no. 1, pp. 21–43, 2014.
- [8] "The new york city taxicab fact book," <http://www.schallerconsult.com/taxi/taxifb.pdf>.
- [9] D.Zhang *et al.*, "coride: carpool service with a win-win fare model for large-scale taxicab networks," in *ACM SenSys*, 2013.
- [10] <http://blogs.mathworks.com/loren/2014/09/06/analyzing-uber-ride-sharing-gps-data/>.
- [11] <http://www.slideshare.net/ivecoitaly/glider-presentation>.
- [12] D. L.Applegate *et al.*, *The Traveling Salesman Problem: A Computational Study (Princeton Series in Applied Mathematics)*, 2007.
- [13] G.Berbeglia *et al.*, "Dynamic pickup and delivery problems," *European Journal of Operational Research*, vol. 202, no. 1, pp. 8–15, 2010.
- [14] S.Ma *et al.*, "T-share: A large-scale dynamic taxi ridesharing service," in *ICDE*, 2013, pp. 410–421.
- [15] M.Hifi *et al.*, "A linear programming approach for the three-dimensional bin-packing problem," *Electronic Notes in Discrete Mathematics*, vol. 36, pp. 993–1000, 2010.
- [16] A.Pal and K.Kant, "F² π : A physical internet architecture for fresh food distribution networks," submitted for publication.
- [17] AMPL, <http://ampl.com/products/solvers/>.
- [18] <http://www.mathworks.com/products/matlab/>.
- [19] <http://www.mathworks.com/matlabcentral/fileexchange/31814-mdmtpv-ga-multiple-depot-multiple-traveling-salesmen-problem-solved-by-genetic-algorithm>.
- [20] <https://github.com/dima42/uber-gps-analysis/tree/master/gpsdata>.
- [21] B.Montreuil *et al.*, "Towards a physical internet: the impact on logistics facilities and material handling systems design and innovation," in *IMHRC*, 2010.
- [22] R.Sarraj *et al.*, "Analogies between internet network and logistics service networks: challenges involved in the interconnection," *Journal of Intelligent Manufacturing*, vol. 25, no. 6, pp. 1207–1219, 2014.
- [23] A.Pal and K.Kant, "Networking in the real world: Unified modeling of information and commodity distribution networks," submitted for publication.
- [24] A.Pal and K.Kant, "On bridging information networks and perishable commodity distribution networks," submitted for publication.
- [25] K.Yamamoto *et al.*, "Adaptive routing of cruising taxis by mutual exchange of pathways," in *KES*, 2008, pp. 559–566.
- [26] J.Yuan *et al.*, "Where to find my next passenger?" in *UbiComp*, 2011.
- [27] J.Yuan *et al.*, "An interactive-voting based map matching algorithm," in *MDM*, 2010, pp. 43–52.
- [28] <http://www.supershuttle.com/>.